

标准型盘形悬式钢化玻璃绝缘子  
Standard disk suspension-type glass insulator



图1 Fig. 1



图2 Fig. 2

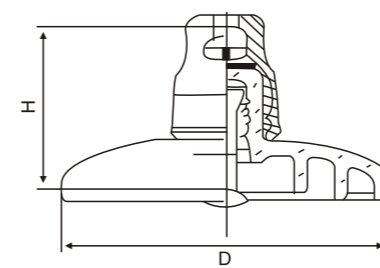

图3 Fig. 3

**标准型** 盘形悬式钢化玻璃绝缘子主要技术参数 (GB及IEC)

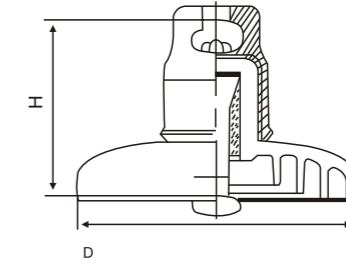
Main technical parameters (GB and IEC) of standard disk suspension-type glass insulator

绝缘子型号	IEC标准绝缘子	图号	公称直径 D (mm)	结构高度 H (mm)	公称爬电距离 L (mm)	连接标记 (mm)	额定机械破坏负荷 (kN)	逐个拉伸负荷试验 (kN)	工频干耐受电压 (kV)	工频湿耐受电压 (kV)	雷电冲击耐受电压 (kV)	冲击过电压耐受电压 (p.u.)	最小工频击穿耐受电压 (kV)	无线电干扰 10kV 1MHz (μV)	可见电晕电压脚/帽 (kV)	工频电弧试验	绝缘子单片重量 (kg)
Ruitai Type	IEC Type	Drawing Number	Diameter D (mm)	Spacing H (mm)	Creepage Distance L (mm)	Size of Coupling (mm)	Mechanical Failing Load (kN)	Mechanical Routine Test (kN)	Power Frequency Withstand Voltage (DRY) (kV)	Power Frequency Withstand Voltage (WET) (kV)	Lighting Impulse Withstand Voltage (kV)	Impulse Withstand Voltage (p.u.)	Min Power Frequency Puncture Voltage (kV)	Radio Interference Voltage (10kV, 1MHz) (μV)	Corona Test (pin & cap) (kV)	Power Frequency Electric Arc Test	Net Weight Per Unit (kg)
LXP1-70	U70BL/146	1	255	146	320	16	70	35	70	40	100	2.8	130	≤50	18/22	0.12s/20kA	3.6
LXP2-70	U70BS/127	1	255	127	320	16	70	35	70	40	100	2.8	130	≤50	18/22	0.12s/20kA	3.5
LXP-100	U100BL/146	1	255	146	320	16	100	50	70	40	100	2.8	130	≤50	18/22	0.12s/20kA	4.0
LXP2-100	U100BS/127	1	255	127	320	16	100	50	70	40	100	2.8	130	≤50	18/22	0.12s/20kA	4.0
LXP-120	U120B/146	1	255	146	320	16	120	60	70	40	100	2.8	130	≤50	18/22	0.12s/20kA	4.2
LXP2-120	U120B/127	1	255	127	320	16	120	60	70	40	100	2.8	130	≤50	18/22	0.12s/20kA	4.0
LXP-160	U160BL/170	1	280	170	400	20	160	80	75	45	110	2.8	130	≤50	18/22	0.12s/20kA	6.5
LXP1-160	U160B/155	1	280	155	450	20	160	80	75	45	110	2.8	130	≤50	18/22	0.12s/20kA	6.3
LXP3-160	U160B/155	1	280	155	400	20	160	80	75	45	110	2.8	130	≤50	18/22	0.12s/20kA	6.3
LXP4-160	U160BS/146	1	280	146	400	20	160	80	75	45	110	2.8	130	≤50	18/22	0.12s/20kA	6.3
LXP2-210	U210B/170	1	280	170	460	20	210	105	85	45	125	2.8	130	≤50	18/22	0.12s/20kA	6.9
LXP3-210	U210B/170	1	280	170	400	20	210	105	75	45	110	2.8	130	≤50	18/22	0.12s/20kA	6.9
LXP-240	U240B/170	2	280	170	400	24	240	120	75	45	110	2.8	130	≤50	18/22	0.12s/20kA	6.9
LXP2-240	U240B/170	2	280	170	460	24	240	120	85	50	110	2.8	130	≤50	18/22	0.12s/20kA	6.9
LXP-300	U300B/195	3	320	195	485	24	300	150	85	50	130	2.8	130	≤50	18/22	0.12s/20kA	10.6
LXP-420	U420/205	3	360	205	550	28	420	210	90	55	140	2.8	130	≤50	18/22	0.12s/20kA	16.0
LXP-550	U550B/240	3	380	240	620	32	550	275	95	55	145	2.8	130	≤50	18/22	0.12s/20kA	21.5

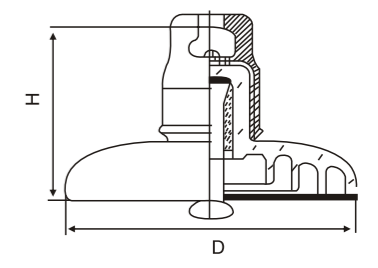

**耐污型盘形悬式钢化玻璃绝缘子**  
Stain-resistant disk suspension-type glass insulator



图4 Fig. 4



图5 Fig. 5

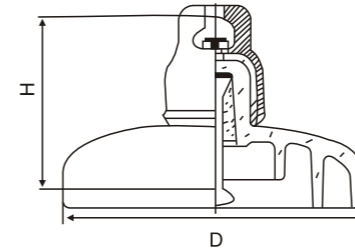

图6 Fig. 6

**耐污型 盘形悬式钢化玻璃绝缘子主要技术参数 (GB及IEC)**

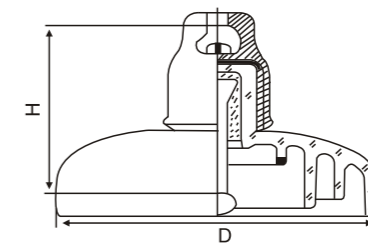
Main technical parameters (GB and IEC) of stain-resistant disk suspension-type glass insulator

绝缘子 型号	IEC标准 绝缘子	图号	公称 直径 D (mm)	结构 高度 H (mm)	公称 爬电 距离 L (mm)	连接 标记 (mm)	额定机 械破坏 负荷 (kN)	逐个拉 伸负荷 试验 (kN)	工频干 耐受电 压 (kV)	工频湿 耐受电 压 (kV)	雷电冲 击耐受 电压 (kV)	冲击过 电压耐 受电压 (p.u.)	最小工 频击穿 耐受电 压 (kV)	无线电 干扰 10kV 1MHz ( $\mu$ V)	可见电 晕电压 脚/帽 (kV)	工频电 弧试验	绝缘 子单 片重 量 (kg)
Ruitai Type	IEC Type	Drawing Number	Diameter D (mm)	Spacing H (mm)	Creepage Distance L (mm)	Size of Coupling (mm)	Mechanical Failing Load (kN)	Mechanical Routine Test (kN)	Power Frequency Withstand Voltage (DRY) (kV)	Power Frequency Withstand Voltage (WET) (kV)	Lighting Impulse Withstand Voltage (kV)	Impulse Withstand Voltage (p.u.)	Min Power Frequency Puncture Voltage (kV)	Radio Interference Voltage (10kV, 1MHz) ( $\mu$ V)	Corona Test (pin & cap) (kV)	Power Frequency Electric Arc Test	Net Weight Per Unit (kg)
LXWP4-70	U70BP/146	4	260	146	400	16	70	35	80	45	110	2.8	130	$\leq 50$	18/22	0.12s/20kA	5.0
LXWP5-70	U70BLP/146	4	280	146	450	16	70	35	85	50	125	2.8	130	$\leq 50$	18/22	0.12s/20kA	5.5
LXWP6-70	U70BP/146	4	320	146	550	16	70	35	90	55	140	2.8	130	$\leq 50$	18/22	0.12s/20kA	7.5
LXWP3-100	U100BLP/146	4	260	146	400	16	100	50	80	45	110	2.8	130	$\leq 50$	18/22	0.12s/20kA	5.0
LXWP4-100	U100BP/146	4	280	146	450	16	100	50	85	50	125	2.8	130	$\leq 50$	18/22	0.12s/20kA	5.5
LXWP6-100	U100BP/146	4	320	146	550	16	100	50	90	55	140	2.8	130	$\leq 50$	18/22	0.12s/20kA	7.5
LXWP3-120	U120BLP/146	4	260	146	400	16	120	60	80	45	110	2.8	130	$\leq 50$	18/22	0.12s/20kA	5.0
LXWP4-120	U120BLP/146	4	280	146	450	16	120	60	85	50	125	2.8	130	$\leq 50$	18/22	0.12s/20kA	5.5
LXWP6-120	U120BP/146	4	320	146	550	16	120	60	90	55	140	2.8	130	$\leq 50$	18/22	0.12s/20kA	7.5
LXWP3-160	U160BSP/155	4	280	155	450	20	160	80	85	50	125	2.8	130	$\leq 50$	18/22	0.12s/20kA	7.0
LXWP4-160	U160BP/170	4	280	170	450	20	160	80	85	50	125	2.8	130	$\leq 50$	18/22	0.12s/20kA	7.2
LXWP5-160	U160BLP/170	4	320	170	550	20	160	80	90	55	140	2.8	130	$\leq 50$	18/22	0.12s/20kA	9.2
LXWP6-160	U160BP/155	4	320	155	550	20	160	80	90	55	140	2.8	130	$\leq 50$	18/22	0.12s/20kA	9.0
LXWP7-160	U160BSP/146	4	320	146	550	20	160	80	90	55	140	2.8	130	$\leq 50$	18/22	0.12s/20kA	8.8
LXWP3-210	U210BP/170	4	320	170	550	20	210	105	90	55	140	2.8	130	$\leq 50$	18/22	0.12s/20kA	10.0
LXWP3-240	U240BP/170	5	320	170	550	24	240	120	90	55	140	2.8	130	$\leq 50$	18/22	0.12s/20kA	10.5
LXWP4-240	U240BP/170	5	320	170	550	20	240	120	90	55	140	2.8	130	$\leq 50$	18/22	0.12s/20kA	10.5
LXWP-300	U300BP/195	6	390	195	710	24	300	150	95	60	150	2.8	130	$\leq 50$	18/22	0.12s/20kA	14.0
LXWP3-300	U300BP/195	6	380	195	635	24	300	150	95	60	150	2.8	130	$\leq 50$	18/22	0.12s/20kA	14.0
LXWP-420	U420BP/205	6	380	205	620	28	420	210	90	55	140	2.8	130	$\leq 50$	18/22	0.12s/20kA	16.5
LXWP-550	U550BP/240	6	380	240	650	32	550	275	95	55	145	2.8	130	$\leq 50$	18/22	0.12s/20kA	20.5
LXWP1-550	U550BP/240	6	380	240	710	32	550	275	95	60	145	2.8	130	$\leq 50$	18/22	0.12s/20kA	20.5
LXWP-760	U760BP/280	6	420	280	700	36	760	380	90	55	140	2.8	130	$\leq 50$	18/22	0.12s/20kA	22
LXWP-840	U840BP/300	6	420	300	710	40	840	420	95	60	145	2.8	130	$\leq 50$	18/22	0.12s/20kA	24.5

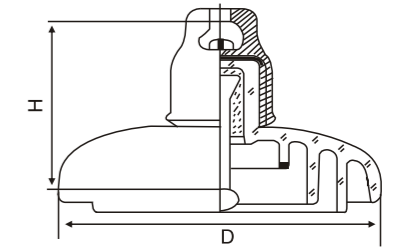
➔ 直流型盘形悬式钢化玻璃绝缘子  
DC disk suspension-type glass insulator



图7 Fig. 7



图8 Fig. 8

**直流型** 盘形悬式钢化玻璃绝缘子主要技术参数 (GB及IEC)

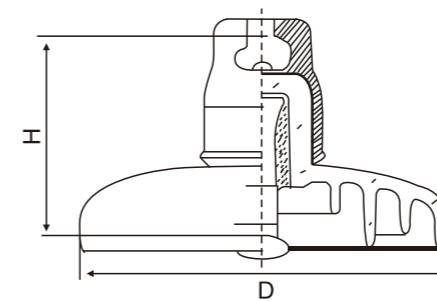
Main technical parameters (GB and IEC) of DC disk suspension-type glass insulator

绝缘子型号	IEC标准型号	图号	公称直径 D (mm)	结构高度 H (mm)	公称爬电距离 L (mm)	连接标记 (mm)	额定机械负荷 (kN)	逐个拉伸负荷试验 (kN)	直流干耐受电压 (kV)	直流湿耐受电压 (kV)	雷电冲击耐受电压 (kV)	冲击电压耐受电压 (p.u.)	SF6 击穿耐受电压 (kV)	无线电干扰 10kV, 1MHz (μV)	直流可见电晕电压脚/帽 (kV)	绝缘子单片重量 (kg)
Ruitai Type	IEC Type	Drawing Number	Diameter D (mm)	Spacing H (mm)	Creepage Distance L (mm)	Size of Coupling (mm)	Mechanical Failing Load (kN)	Mechanical Routine Test (kN)	Anodic DC Dry Withstand Voltage (kV)	Anodic DC Wet Withstand Voltage (kV)	Lighting Impulse Withstand Voltage (kV)	Impulse Withstand Voltage (p.u.)	SF6 Puncture Withstand Voltage (kV)	Radio Interference Voltage (10kV, 1MHz) (μV)	DC Corona Test (pin&cap) (kV)	Net Weight Per Unit (kg)
LXZP-160	U160BP/170H	7	320	170	550	20	160	80	150	65	140	2.8	225	≤50	≥50	9.7
LXZP-210	U210BP/170H	7	320	170	550	20	210	105	150	65	140	2.8	225	≤50	≥50	10.2
LXZP-240	U240BP/170H	7	320	170	550	24	240	120	150	65	140	2.8	225	≤50	≥50	10.5
LXZP-300	U300BP1/195H	7	390	195	710	24	300	150	150	65	140	2.8	225	≤50	≥50	15.4
LXZP1-300	U300BP/195H	7	380	195	635	24	300	150	170	75	155	2.8	255	≤50	≥50	16.0
LXZP-420	U420BP/205H	8	360	205	550	28	420	210	150	65	140	2.8	225	≤50	≥50	14.6
LXZP1-420	U420BP1/205H	8	380	205	620	28	420	210	160	70	150	2.8	240	≤50	≥50	18.9
LXZP-550	U550BP/240H	8	380	240	650	32	550	275	160	70	150	2.8	240	≤50	≥50	19.1
LXZP1-550	U550BP1/240H	8	380	240	710	32	550	275	160	70	150	2.8	240	≤50	≥50	22.0
LXZP-840	U840BP/300	8	420	300	710	40	840	420	170	75	155	2.8	240	≤50	≥50	24.5

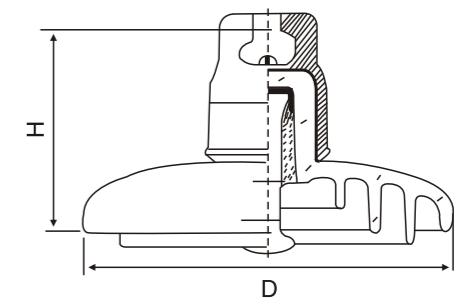
空气动力型盘形悬式钢化玻璃绝缘子  
Aerodynamic disk suspension-type glass insulator



图9 Fig. 9



图10 Fig. 10

空气动力型(交流型) 盘形悬式钢化玻璃绝缘子主要技术参数 (GB及IEC)

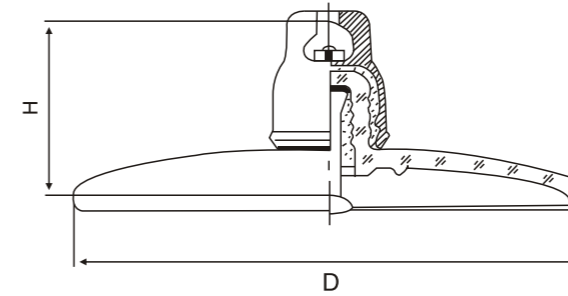
The Parameters for Open Air Profile ( AC ) Toughened Glass Suspension Insulator (GB & IEC)

绝缘子型号	IEC标准绝缘子	图号	公称直径 D (mm)	结构高度 H (mm)	公称爬电距离 L (mm)	连接标记 (mm)	额定机械破坏负荷 (kN)	逐个拉伸负荷试验 (kN)	工频干耐受电压 (kV)	工频湿耐受电压 (kV)	雷电冲击耐受电压 (kV)	冲击过电压耐受电压 (p.u.)	最小工频击穿电压 (kV)	无线电干扰 10kV 1MHz (μV)	可见电晕电压/帽 (kV)	工频电弧试验	绝缘子单片重量 (kg)
Ruitai Type	IEC Type	Drawing Number	Diameter D (mm)	Spacing H (mm)	Creepage Distance L (mm)	Size of Coupling (mm)	Mechanical Failing Load (kN)	Mechanical Routine Test (kN)	Power Frequency Withstand Voltage (DRY) (kV)	Power Frequency Withstand Voltage (WET) (kV)	Lighting Impulse Withstand Voltage (kV)	Impulse Withstand Voltage (p.u.)	Min Power Frequency Puncture Voltage (kV)	Radio Interference Voltage (10kV, 1MHz) (μV)	Corona Test (pin & cap) (kV)	Power Frequency Electric Arc Test	Net Weight Per Unit (kg)
LXAP-70	U70BP/146M	9	380	146	365	16	70	35	55	45	90	2.8	130	≤50	18/22	0.12s/20kA	5.3
LXAP-100	U100BP/146M	9	380	146	365	16	100	50	55	45	90	2.8	130	≤50	18/22	0.12s/20kA	5.2
LXAP-120	U120BP/146M	9	380	146	365	16	120	60	55	45	90	2.8	130	≤50	18/22	0.12s/20kA	5.4
LXAP-160	U160BP/155M	10	420	155	380	20	160	80	60	50	95	2.8	130	≤50	18/22	0.12s/20kA	7.2
LXAP-210	U210BP/170M	10	420	170	380	20	210	105	60	50	95	2.8	130	≤50	18/22	0.12s/20kA	7.3
LXAP-240	U240BP/170M	10	420	170	380	24	240	120	60	50	95	2.8	130	≤50	18/22	0.12s/20kA	7.5

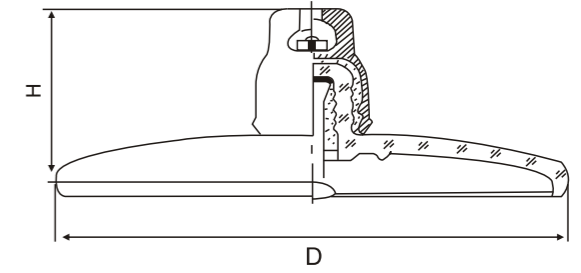
空气动力型(直流型) 盘形悬式钢化玻璃绝缘子主要技术参数 (GB 及 IEC)

The Parameters for Open Air Profile ( DC ) Toughened Glass Suspension Insulator (GB & IEC)

绝缘子型号	IEC标准型号	图号	公称直径 D (mm)	结构高度 H (mm)	公称爬电距离 L (mm)	连接标记 (mm)	额定机械破坏负荷 (kN)	逐个拉伸负荷试验 (kN)	直流干耐受电压 (kV)	直流湿耐受电压 (kV)	雷电冲击耐受电压 (kV)	冲击过电压耐受电压 (p.u.)	SF6 击穿耐受电压 (kV)	无线电干扰 10kV 1MHz (μV)	直流可见电晕电压/帽 (kV)	绝缘子单片重量 (kg) N.W.
Ruitai Type	IEC Type	Drawing Number	Diameter D (mm)	Spacing H (mm)	Creepage Distance L (mm)	Size of Coupling (mm)	Mechanical Failing Load (kN)	Mechanical Routine Test (kN)	Anodic DC Dry Withstand Voltage (kV)	Anodic DC Wet Withstand Voltage (kV)	Lighting Impulse Withstand Voltage (kV)	Impulse Withstand Voltage (p.u.)	SF6 Puncture Withstand Voltage (kV)	Radio Interference Voltage (10kV, 1MHz) (μV)	DC Corona Test (pin & cap) (kV)	Net Weight Per Unit (kg)
LXAZP-160	U160BP/170M	10	420	170	390	20	160	80	140	60	110	2.8	210	≤50	≥50	10
LXAZP-210	U210BP/170M	10	420	170	390	20	210	105	140	60	110	2.8	210	≤50	≥50	10.4



双伞型盘形悬式钢化玻璃绝缘子  
Double-umbrella disk suspension-type glass insulator



图11 Fig. 11

双伞型 盘形悬式钢化玻璃绝缘子主要技术参数 (GB及IEC)

Main technical parameters (GB and IEC) of double-umbrella disk suspension-type glass insulator

绝缘子 型号	图号	公称 直径 D (mm)	结构 高度 H (mm)	公称 爬电 距离 L (mm)	连接 标记 (mm)	额定机 械破坏 负荷 (kN)	逐个拉 伸负荷 试验 (kN)	工频干 耐受电 压 (kV)	工频湿 耐受电 压 (kV)	雷电冲 击耐受 电压 (kV)	冲击过 电压耐 受电压 (p.u.)	最小工 频击穿 耐受电 压 (kV)	无线电 干扰 10kV 1MHz ( $\mu$ V)	可见电 晕电压 脚帽 (kV)	工频电 弧试验	绝缘 子单 片重 量 (kg)
Ruitai Type	Drawing Number	Diameter D (mm)	Spacing H (mm)	Creepage Distance L (mm)	Size of Coupling (mm)	Mechanical Failing Load (kN)	Mechanical Routine Test (kN)	Power Frequency Withstand Voltage (DRY) (kV)	Power Frequency Withstand Voltage (WET) (kV)	Lighting Withstand Voltage (kV)	Impulse Withstand Voltage (p.u.)	Min Power Frequency Puncture Voltage (kV)	Radio Interference Voltage (10kV, 1MHz) ( $\mu$ V)	Corona Test (pin & cap) (kV)	Power Frequency Electric Arc Test	Net Weight Per Unit (kg)
UG70B146/450D 16R	11	280	146	450	16	70	35	80	45	120	2.8	130	$\leq 50$	18/22	0.12s/20kA	6.3
UG100B146/450D 16R	11	280	146	450	16	100	50	80	45	120	2.8	130	$\leq 50$	18/22	0.12s/20kA	6.3
UG120B146/450D 16R	11	280	146	450	16	120	60	80	45	120	2.8	130	$\leq 50$	18/22	0.12s/20kA	6.3
UG160B170/450D 20R	11	300	170	450	20	160	80	85	45	130	2.8	130	$\leq 50$	18/22	0.12s/20kA	8.4
UG210B170/450D 20R	11	300	170	450	20	210	105	85	45	130	2.8	130	$\leq 50$	18/22	0.12s/20kA	9.0
UG300B195/480D 24R	11	330	195	480	24	300	150	85	50	130	2.8	130	$\leq 50$	18/22	0.12s/20kA	13.0

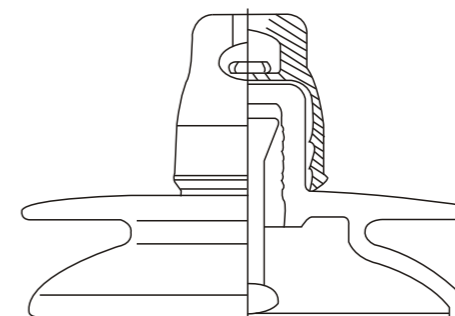

三伞型盘形悬式钢化玻璃绝缘子  
Three-umbrella disk suspension-type glass insulator



图12 Fig. 12

三伞型(交流型) 盘形悬式钢化玻璃绝缘子主要技术参数 (GB及IEC)

The Parameters of Three-shells Type ( AC ) Toughened Glass Suspension Insulator (GB & IEC)

绝缘子型号	图号	公称直径 D (mm)	结构高度 H (mm)	公称爬电距离 L (mm)	连接标记 (mm)	额定机械破坏负荷 (kN)	逐个拉伸负荷试验 (kN)	工频干耐受电压 (kV)	工频湿耐受电压 (kV)	雷电冲击耐受电压 (kV)	冲击过电压耐受电压 (p.u.)	最小工频击穿耐受电压 (kV)	无线电干扰 10kV 1MHz (μV)	可见电晕电压脚/帽 (kV)	工频电弧试验	绝缘子单片重量 (kg)
Ruitai Type	Drawing Number	Diameter D (mm)	Spacing H (mm)	Creepage Distance L (mm)	Size of Coupling (mm)	Mechanical Failing Load (kN)	Mechanical Routine Test (kN)	Power Frequency Withstand Voltage (DRY) (kV)	Power Frequency Withstand Voltage (WET) (kV)	Lighting Impulse Withstand Voltage (kV)	Impulse Withstand Voltage (p.u.)	Min Power Frequency Puncture Voltage (kV)	Radio Interference Voltage (10kV, 1MHz) (μV)	Corona Test (pin & cap) (kV)	Power Frequency Electric Arc Test	Net Weight Per Unit (kg)
UG160B170/550T 20R	12	330	170	550	20	160	80	85	50	130	2.8	130	≤50	18/22	0.12s/20kA	8.9
UG210B170/550T 20R	12	330	170	550	20	210	105	85	50	130	2.8	130	≤50	18/22	0.12s/20kA	10.2
UG300B195/550T 24R	12	330	195	550	24	300	150	85	50	130	2.8	130	≤50	18/22	0.12s/20kA	11.3
UG300B195/635T 24R	12	380	195	635	24	300	150	100	60	130	2.8	130	≤50	18/22	0.12s/20kA	15.3
UG420B205/635T 28R	12	400	205	635	28	420	210	110	65	130	2.8	130	≤50	18/22	0.12s/20kA	16.5
UG550B240/635T 32R	12	400	240	635	32	550	275	110	65	130	2.8	130	≤50	18/22	0.12s/20kA	17.5

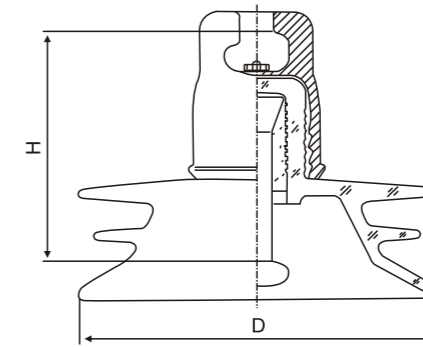
三伞型(直流型) 盘形悬式钢化玻璃绝缘子主要技术参数 (GB及IEC)

The Parameters of Three-shells Type ( DC ) Toughened Glass Suspension Insulator (GB & IEC)

绝缘子型号	图号	公称直径 D (mm)	结构高度 H (mm)	公称爬电距离 L (mm)	连接标记 (mm)	额定机械破坏负荷 (kN)	逐个拉伸负荷试验 (kN)	直流干耐受电压 (kV)	直流湿耐受电压 (kV)	雷电冲击耐受电压 (kV)	冲击过电压耐受电压 (p.u.)	SF6 击穿耐受电压 (kV)	无线电干扰 10kV 1MHz (μV)	直流可见电晕电压脚/帽 (kV)	绝缘子单片重量 (kg) N.W.
Ruitai Type	Drawing Number	Diameter D (mm)	Spacing H (mm)	Creepage Distance L (mm)	Size of Coupling (mm)	Mechanical Failing Load (kN)	Mechanical Routine Test (kN)	Anodic DC Dry Withstand Voltage (kV)	Anodic DC Wet Withstand Voltage (kV)	Lighting Impulse Withstand Voltage (kV)	Impulse Withstand Voltage (p.u.)	SF6 Puncture Withstand Voltage (kV)	Radio Interference Voltage (10kV, 1MHz) (μV)	DC Corona Test (pin & cap) (kV)	Net Weight Per Unit (kg)
DCUG160B170/550T20R	12	330	170	550	20	160	80	140	55	140	2.8	210	≤50	≥50	8.9
DCUG210B170/550T20R	12	330	170	550	20	210	105	140	55	140	2.8	210	≤50	≥50	10.4
DCUG300B195/550T24R	12	330	195	550	24	300	150	150	60	140	2.8	225	≤50	≥50	11.3
DCUG300B195/635T24R	12	380	195	635	24	300	150	150	60	155	2.8	225	≤50	≥50	15.3
DCUG420B205/635T28R	12	400	205	635	28	420	210	150	65	155	2.8	225	≤50	≥50	17.5
DCUG550B240/635T32R	12	400	240	635	32	550	275	160	70	155	2.8	225	≤50	≥50	18.8



地线型盘形悬式钢化玻璃绝缘子  
Earth wire disk suspension-type glass insulator



图13 Fig. 13



图14 Fig. 14

地线型 盘形悬式钢化玻璃绝缘子主要技术参数 (GB及IEC)

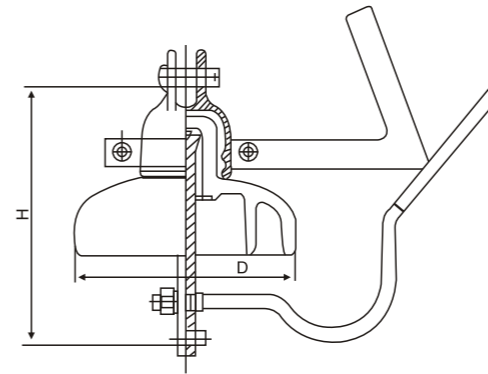
Main technical parameters (GB and IEC) of earth wire disk suspension-type glass insulator

绝缘子 型号	IEC标准 型号	图号	公称 直径 D (mm)	结构 高度 H (mm)	公称 爬电 距离 L (mm)	连接 标记 (mm)	额定机 械破坏 负荷 (kN)	逐个拉 伸负荷 试验 (kN)	工频 湿耐受 电压 (kV)	去掉上电极 工频闪络电压 (kV)		20mm间隙工频 (干或湿)放电电压 (kA)		工频恢复电压2500V (15mm间隙)时电弧 电流(kA)		电极耐弧能力			最小 工频击 穿耐受 电压 (kV)	绝缘 子单 片重 量 (kg)
										干	湿	上限值	下限值	电感性电流	电容性电流	工频电弧(A)	时间(s)	次数		
LXDP-70C	U70C	13	200	210	220	16C	70	35	30	45	25	30	8	35	20	10	0.2	2	130	4.5
LXDP-70CN	U70CN	14	200	210	220	16C	70	35	30	45	25	30	8	35	20	10	0.2	2	130	4.5
LXDP-100C	U100C	13	200	210	220	16C	100	50	30	45	25	30	8	35	20	10	0.2	2	130	4.5
LXDP-100CN	U100CN	14	200	210	220	16C	100	50	30	45	25	30	8	35	20	10	0.2	2	130	4.5

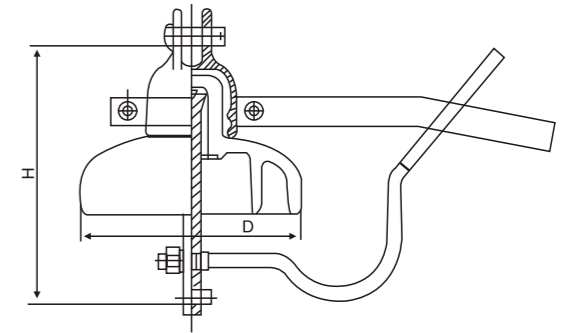
**电气化铁路接触网用玻璃绝缘子**  
Glass insulator for electrified railway catenary

**交流系统用ANSI玻璃绝缘子**  
ANSI glass insulator for AC system



图15 Fig. 15



图16 Fig. 16

**交流系统用ANSI 玻璃绝缘子主要技术参数**

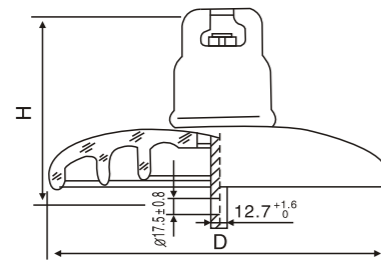
Main technical parameters of glass insulator of ANSI for AC system

绝缘子型号	公称直径 D (mm)		结构高度 H (mm)		公称爬电距离 L (mm)		ANSI 级别	球窝尺寸	机电强度		拉伸负荷试验		机械打击强度		工频干受电压 (kV)	工频湿耐电压 (kV)	临界冲击闪络电压 (kV)		冲击过电压击穿耐电压 (p.u.)	最小工频击穿耐电压 (kV)	无线电干扰 10kV, 1MHz (μV)	绝缘子单片重量 (kg)
	mm	inches	mm	inches	mm	inches			kN	lbs	kN	lbs	N-m	inch-pounds			Positive polarity	Negative				
U70B/146A	255	10	146	5-3/4	320	12-5/8	52-3	B型	70	15000	35	7500	6.0	55	80	50	125	130	2.8	130	≤50	4.0
U100B/146A	255	10	146	5-3/4	320	12-5/8		B型	100	22000	50	11000	6.0	55	80	50	125	130	2.8	130	≤50	4.0
U120B/146A	255	10	146	5-3/4	320	12-5/8	52-5	J型	120	25000	60	12500	7.0	60	80	50	125	130	2.8	130	≤50	4.0
U160B/146A	280	11	146	5-3/4	400	15-3/4	52-8	K型	160	36000	80	18000	10	90	85	55	130	135	2.8	130	≤50	7.0
U210B/156A	280	11	156	6-1/8	400	15-3/4	52-11	K型	220	50000	110	25000	10	90	85	55	140	140	2.8	130	≤50	7.0

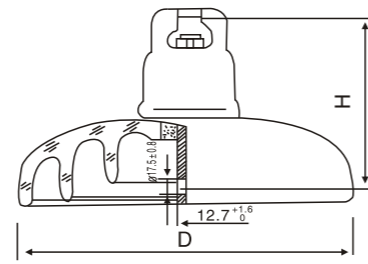
**电气化铁路接触网 用玻璃绝缘子主要技术参数(GB及IEC)**

Main technical parameters (GB and IEC) of glass insulator for electrified railway catenary

绝缘子型号	图号	公称直径 D (mm)	结构高度 H (mm)	公称爬电距离 L (mm)	连接标记 (mm)	额定机械破坏负荷 (kN)	逐个拉伸负荷试验 (kN)	工频干耐电压 (kV)	工频湿耐电压 (kV)	雷电冲击耐电压 (kV)	冲击过电压耐电压 (p.u.)	最小工频击穿耐电压 (kV)	无线电干扰 10kV, 1MHz (μV)	可见电晕电压脚/帽 (kV)	工频电弧试验	绝缘子单片重量 (kg)
Ruitai Type	Drawing Number	Diameter D (mm)	Spacing H (mm)	Creepage Distance L (mm)	Size of Coupling (mm)	Mechanical Falling Load (kN)	Mechanical Routine Test (kN)	Power Frequency Withstand Voltage (DRY) (kV)	Power Frequency Withstand Voltage (WET) (kV)	Lighting Impulse Withstand Voltage (kV)	Impulse Withstand Voltage (p.u.)	Min Power Frequency Puncture Voltage (kV)	Radio Interference Voltage (10kV, 1MHz) (μV)	Corona Test (pin & cap) (kV)	Power Frequency Electric Arc Test	Net Weight Per Unit (kg)
LXP-70T	15	255	146	320	铁帽为16W/16R球形连接, 钢脚为16C连接	70	35	70	40	100	2.8	130	≤50	18/22	0.12s/20kA	4.4
LXWP-70T	16	255	146	400	铁帽为16W/16R球形连接, 钢脚为16C连接	70	35	80	45	110	2.8	130	≤50	18/22	0.12s/20kA	5.0
LXWP1-70T	16	280	146	450	铁帽为16W/16R球形连接, 钢脚为16C连接	70	35	85	50	125	2.8	130	≤50	18/22	0.12s/20kA	5.5
LXP-80T	15	255	146	320	铁帽为16W/16R球形连接, 钢脚为16C连接	80	40	70	40	100	2.8	130	≤50	18/22	0.12s/20kA	4.0
LXWP-80T	16	255	146	400	铁帽为16W/16R球形连接, 钢脚为16C连接	80	40	80	45	110	2.8	130	≤50	18/22	0.12s/20kA	5.0
LXWP1-80T	16	280	146	450	铁帽为16W/16R球形连接, 钢脚为16C连接	80	40	85	50	125	2.8	130	≤50	18/22	0.12s/20kA	5.5



**交流型盘形悬式钢化玻璃绝缘子型号说明**  
Model description of AC Toughened Glass Suspension Insulator

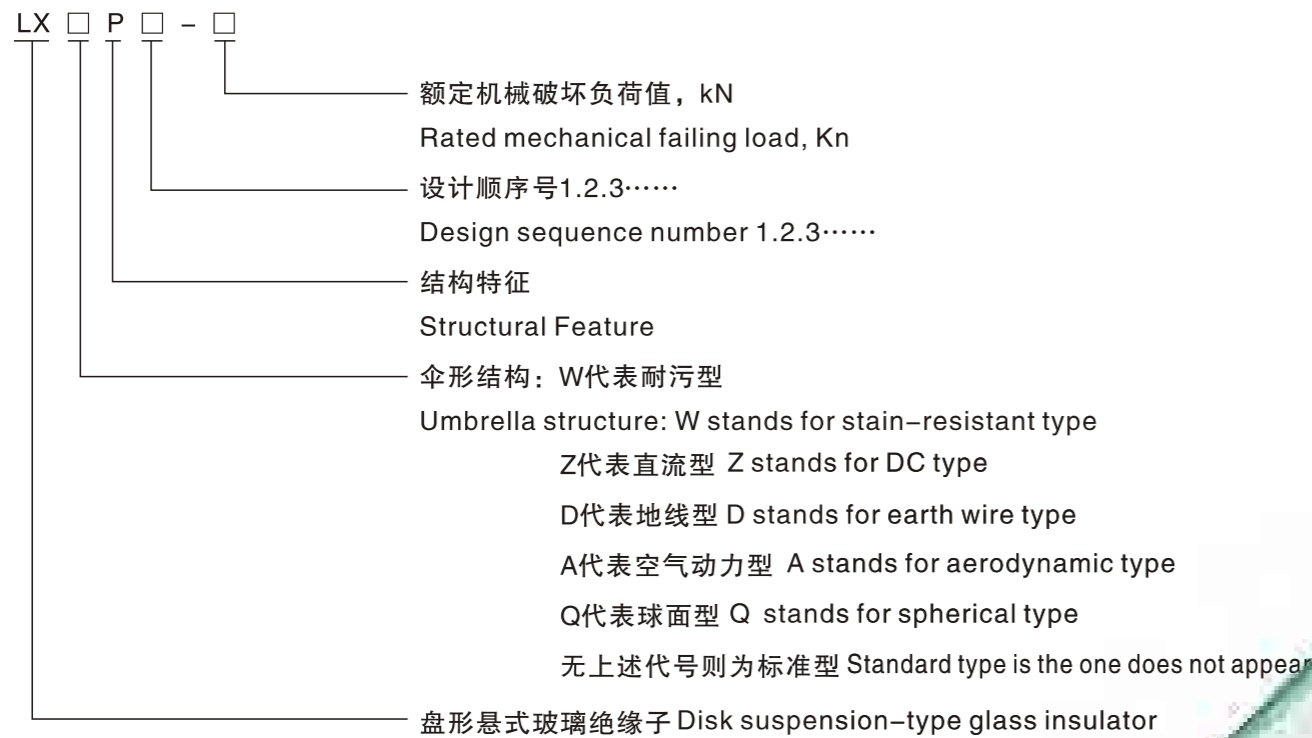

**直流型盘形悬式钢化玻璃绝缘子型号说明**  
Model description of DC Toughened Glass Suspension Insulator

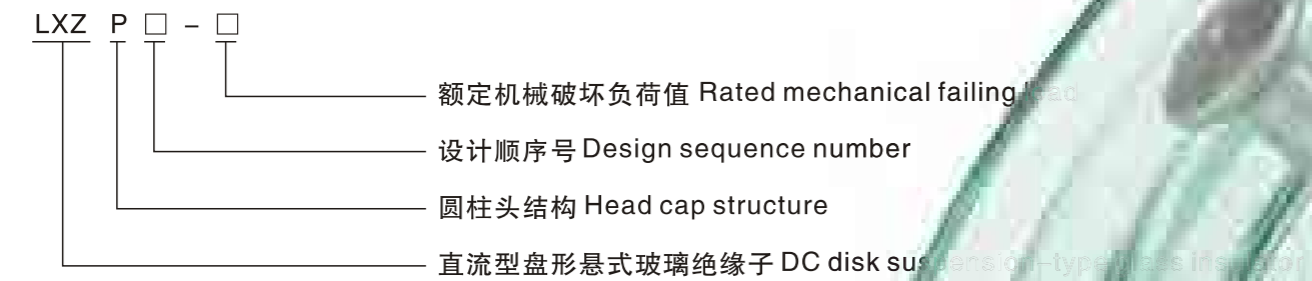

※ T为电气化铁道用耳环形绝缘子或三伞型  
T stands for annular insulator for electrified railway or three-umbrella type

※ D为标准型大盘径绝缘子或双伞型  
D stands for standard large disk diameter insulator or double-umbrella type

**交流外伞型盘形悬式钢化玻璃绝缘子型号说明**  
Model Description of AC Outer-rib-type Toughened Glass Suspension

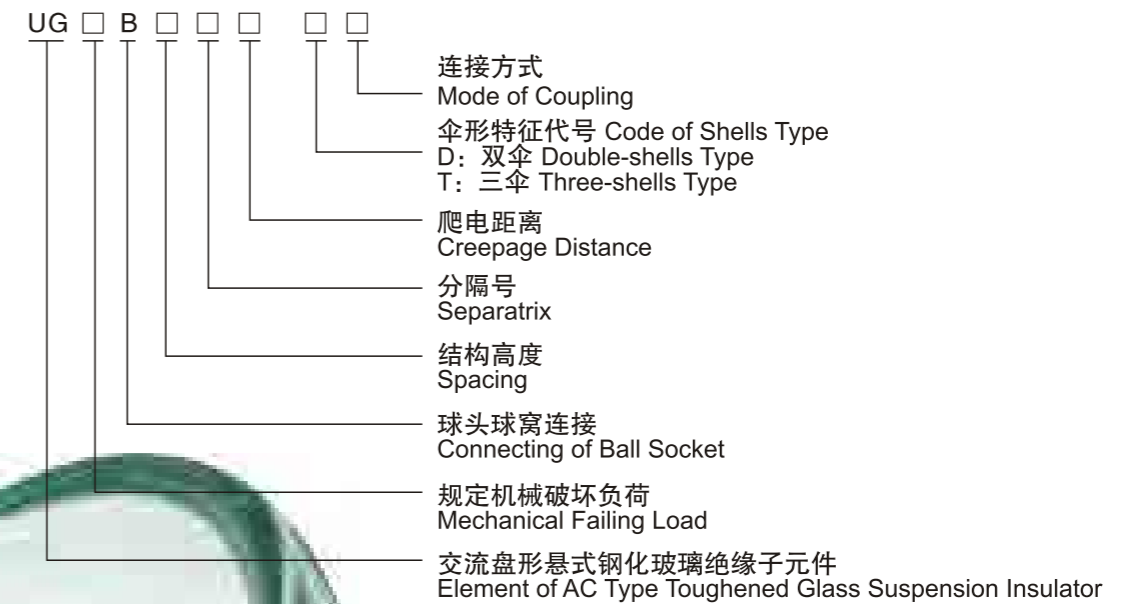

**直流外伞型盘形悬式钢化玻璃绝缘子型号说明**  
Model Description of DC Outer-rib-type Toughened Glass Suspension

