

STRAIN CLAMP

1. Dead End Clamp for ACSR Conductor (compression type)

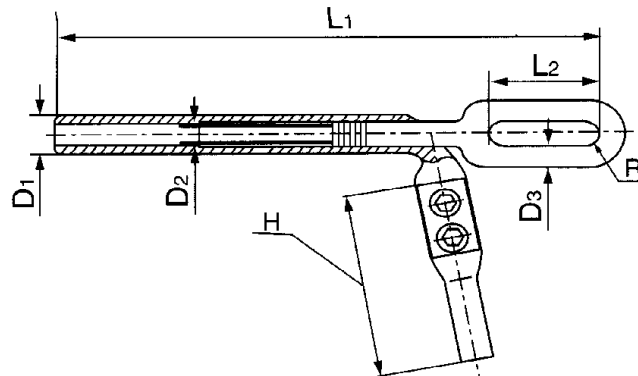

Cat No	Suitable Conductor	Dimensions(mm)							Slip strength (KN)	Weight (Kg)
		D1	D2	D3	L1	L2	R	H		
NY-70/40	LGJ-70/40	30	16	16	400	55	10	220	55	1.70
NY-95/55	LGJ-95/55	34	20	18	406	55	10	220	74	2.43
NY-120/70	LGJ-120/70	36	20	18	445	65	12	225	94	2.70
NY-150/25	LGJ-150/25	32	16	16	325	55	10	225	51	1.80
NY-185/25	LGJ-185/25	34	16	16	340	55	10	225	57	2.0
NY-185/30	LGJ-185/30	34	16	16	350	55	10	225	61	2.0
NY-240/25	LGJ-240/25	36	16	16	400	55	10	240	63	2.1
NY-240/30	LGJ-240/30	36	16	18	455	55	10	240	72	2.5
NY-240/40	LGJ-240/40	36	16	18	469	55	10	240	79	2.5
NY-240/55	LGJ-240/55	36	20	18	481	55	11	250	97	2.7
NY-300/15	LGJ-300/15	40	14	16	440	50	11	265	65	2.6
NY-300/20	LGJ-300/20	40	14	18	465	55	11	265	72	2.8
NY-300/25	LGJ-300/25	40	14	18	465	55	11	265	79	2.9
NY-300/40	LGJ-300/40	40	16	18	487	55	11	265	88	3.1
NY-300/50	LGJ-300/50	40	18	18	510	65	12	265	98	3.1
NY-300/70	LGJ-300/70	42	22	18	545	70	12	265	122	3.9
NY-400/20	LGJ-400/20	45	14	18	486	55	13	280	84	3.6
NY-400/25	LGJ-400/25	45	14	20	496	55	13	80	91	3.7
NY-400/35	LGJ-400/35	45	16	18	524	65	13	280	99	4.0
NY-400/50	LGJ400/50	48	20	18	537	65	13	280	117	4.2
NY-400/60	LGJ-400/60	48	22	22	538	70	13	280	128	5.4
NY-400/95	LGJ-400/95	48	26	26	631	80	14	280	163	6.6

The body and jumper are made of extruded aluminum or aluminum alloy tube,. The anchor is made of drop forged steel, hot-dip galvanized .

2. Dead End Clamp for ACSR Conductor (compression type)

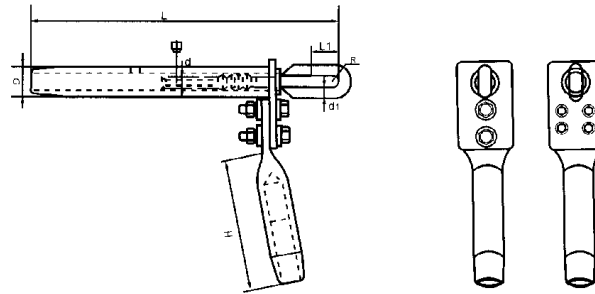

Cat No	Suitable Conductor	Dimensions(mm)							Slip strength (KN)	Weight (Kg)
		D	d1	d	L	L1	R	H		
NY-500/35	LGJ-500/35	52	16	20	617	65	14	275	114	5.3
NY-500/45	LGJ-500/45	52	18	20	627	70	14	275	122	5.4
NY-500/65	LGJ-500/65	52	22	22	657	70	15	275	146	6.2
NY-630/45	LGJ-630/45	60	18	22	675	70	16	300	141	7.7
NY-630/55	LGJ-630/55	60	20	22	675	70	16	300	156	7.9
NY-630/80	LGJ-630/80	60	24	26	730	80	17	300	183	9.1
NY-800/55	LGJ-800/55	65	20	26	750	80	19	345	182	10.5
NY-800/70	LGJ-800/70	65	22	26	755	85	19	345	197	10.6
NY-800/100	LGJ-800/100	65	26	30	765	85	19	345	229	12.1

The body and jumper are made of aluminum,. Other parts are made of hot-dip galvanized steel .

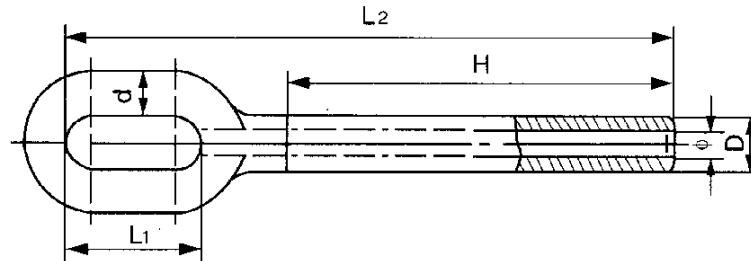

Cat No	Suitable Conductor		Dimensions(mm)						Slip strength (KN)	Weight (Kg)
	Standard	Remark	Φ	D	d	L1	L2	H		
NY-35G	GB1200-88 1270N/mm ²	1x7-7.8	8.4	16	16	50	195	115	45	0.52
NY-55G		1x7-9.6	10.2	20	16	50	220	140	70	0.70
NY-80G		1x19-11.5	12.2	24	18	55	260	170	100	1.30
NY-100GC	GB1200-88 1370N/mm ²	1x19-13	13.7	28	22	70	325	220	130	1.64
NY-125GC		1x19-14.5	15.2	32	24	80	360	250	165	1.70
NY-150GC		1x19-16	16.7	34	24	80	395	270	200	2.52
NY-50G	GB1200-75 125kg/mm ²	1x7-9	9.7	18	16	50	220	130	60	0.63
NY-70G		1x19-11	11.7	22	18	55	245	155	80	1.02
NY-100G		1x19-13	13.7	26	20	65	290	185	120	1.63
NY-120G		1x19-14	14.7	28	22	70	310	195	140	1.90
NY-135G		1x19-15	15.7	30	22	70	330	215	215	2.30

Suitable for GSW.,made of hot-dip galvanized steel .

3.Compression Dead-End Clamp

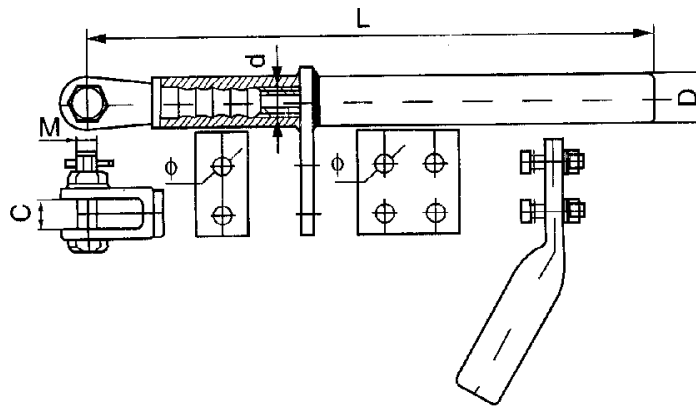

Cat No	Suitable Conductor	Dimensions(mm)						Slip strength (KN)	Weight (Kg)
		D	d	L	C	Φ	M		
NYC-95/15	DIN48204-95/15	32	14	365	24	14	16	33.32	1.65
NYC-95/55	DIN48204-95/55	34	20	405	24	14	16	73.95	2.50
NYC-120/20	DIN48204-120/20	32	14	385	24	14	16	42.54	2.10
NYC-120/70	DIN48204-120/70	42	22	475	24	14	20	93.20	4.10
NYC-150/25	DIN48204-150/25	34	14	405	24	14	16	51.49	2.25
NYC-170/40	DIN48204-170/40	34	16	410	24	14	16	71.53	2.30
NYC-185/30	DIN48204-185/30	34	16	410	24	14	16	61.70	2.60
NYC-240/40	DIN48204-240/40	38	16	460	24	14	18	80.52	3.05
NYC-240/55	DIN48204-240/55	38	20	460	24	14	20	97.00	3.10
NYC-300/50	DIN48204-300/50	42	20	480	24	14	20	99.72	3.76
NYC-340/30	DIN48204-340/30	42	16	480	24	14	20	86.58	3.60
NYC-350/79	DIN48204-350/79	48	24	520	24	14	22	157.96	4.52
NYC-360/60	DIN48204-360/60	48	20	520	24	14	20	131.02	4.31
NYC-435/55	DIN48204-435/55	48	20	520	24	14	20	127.16	4.35
NYC-450/40	DIN48204-450/40	48	16	520	24	14	20	112.53	4.30
NYC-490/65	DIN48204-490/65	52	22	575	24	14	22	142.68	5.30
NYC-490/110	DIN48204- 490/110	60	26	590	24	14	24	211.55	6.70

The body and jumper clamp are made of aluminum, cotter-pin is made of stainless steel, other parts are made of hot-dip galvanized steel .

4. Dead End Clamp for ACSR Conductor (compression type)

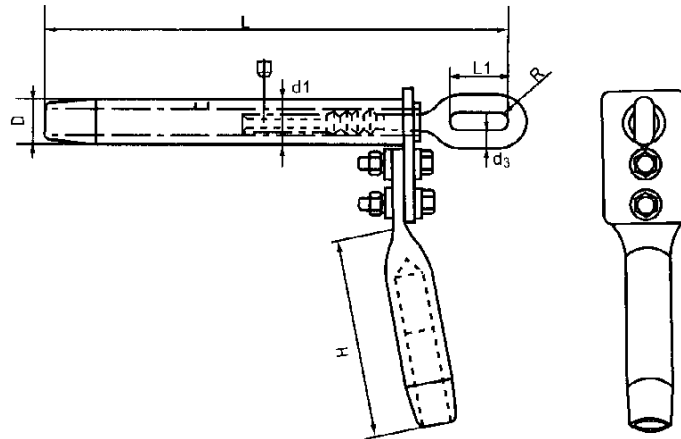

Cat No	Suitable Conductor	Dimensions(mm)							Slip strength (KN)	Weight (Kg)
		D	d1	d3	L	L1	R	H		
NY-170	LINNET	32	16	16	430	60	10	240	60.20	2.9
NY-183	LYNX	32	18	18	440	65	11	240	75.71	2.9
NY-240	HAWK	36	18	18	480	65	11	250	82.48	3.2
NY-241	HEN	36	20	20	490	78	12	250	99.44	3.3
NY-248	LARK	36	20	18	490	68	11	250	85.93	3.3
NY-282	DOVE	40	18	20	500	78	12	280	100.64	3.5
NY-264	BEAR	40	22	20	520	78	12	280	105.83	3.6
NY-306	SQUAB	40	18	20	500	78	12	280	102.98	3.5
NY-322	GROSBEAK	40	20	22	540	83	13	280	107.17	3.9
NY-376	TEAL	45	22	22	550	83	13	280	126.75	4.1
NY-402	CONDOR	45	20	22	590	83	13	300	119.29	4.2
NY-428	ZEBRA	48	20	22	600	83	13	300	125.31	4.3
NY-445	REDWING	48	24	24	600	95	15	300	146.32	4.5
NY-468	DRAKE	48	22	22	620	83	13	320	132.52	5.4
NY-494	MALLARD	48	26	24	620	95	15	320	163.00	5.4
NY-483	RAIL	48	18	20	620	78	13	340	109.60	6.4
NY-564	BLUEJAY	52	18	22	620	78	13	340	126.75	6.8
NY-546	CARDINAL	52	20	24	620	95	15	320	143.52	6.8
NY-604	GRACKLE	60	26	24	670	95	15	350	178.93	7.2

The body and jumper clamp are made of aluminum, other parts are made of hot-dip galvanized steel .

5. Dead End Clamp for ACSR Conductor (hydraulic compression type)

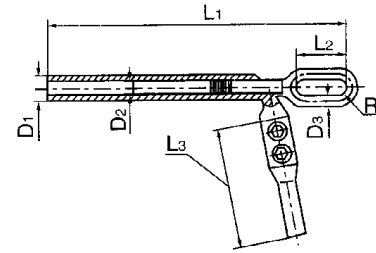

Cat No	Suitable Conductor	Dimensions(mm)							Slip strength (KN)	Weight (Kg)
		D1	D2	D3	L1	L2	L3	R		
NY-70/40BG	ACSR/AS-70/40	34	16	16	455	65	180	8.5	57.8	0.4
NY-80/47BG	ACSR/AS-80/47	36	18	16	460	65	230	10	64.6	2.6
NY-95/55BG	ACSR/AS-95/55	36	20	18	460	65	230	11	74.0	2.9
NY-185/30BG	ACSR/AS-185/30	36	16	16	530	65	220	9	62.9	2.9
NY-240/40BG	ACSR/AS-240/40	38	18	18	565	65	240	12	81.6	3.3
NY-300/25BG	ACSR/AS-300/25	42	14	18	580	65	265	11	74.4	3.6
NY-300/40BG	ACSR/AS-300/40	42	18	18	580	65	265	13	90.0	3.8
NY-300/50BG	ACSR/AS-300/50	42	18	18	595	78	265	13	101.0	4.1
NY-300/70BG	ACSR/AS-300/70	42	22	20	610	78	260	13	117.8	4.4
NY-400/35BG	ACSR/AS-400/35	48	18	20	615	78	280	13	99.0	5.2
NY-400/50BG	ACSR/AS-400/50	48	20	20	625	78	280	13	117.0	5.4

The body and jumper clamp are made of aluminum,. Other parts are made of hot-dip galvanized steel .

6. Dead End Clamp for ACSR Conductor (hydraulic compression type)

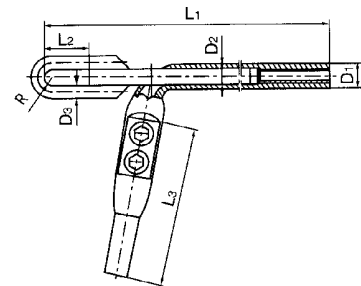

Cat No	Suitable Conductor	Dimensions(mm)							Slip strength (KN)	Weight (Kg)
		D1	D2	D3	L1	L2	L3	R		
NY-50BG	LB20J-50	32	18	16	275	64	195	9	55.8	1.7
NY-70BG	LB 27J-70	32	20	16	380	50	185	10	65.8	1.7
NY-80BG	LB 20J-80	36	24	18	417	67	185	12	85.0	2.5
NY-95BG	LB 40J-95	34	24	16	430	60	200	12	56.0	2.5
NY-120BG	LB 27J-120	36	26	20	475	70	210	13	112.0	3.0
NY-150BG	LB 40J-150	42	26	20	530	75	265	13	86.0	3.8
NY-150.1BG	LB 20J-150	45	32	30	560	90	280	16	167.0	7.3
NY-240BG	LB 27J-240	50	36	30	620	110	280	18	221.3	7.8

The body ,aluminum bush and made of jumper clamp are aluminum,. Other parts are made of hot-dip galvanized steel .

7. Aluminium Alloy Strain Clamp (bolted type)

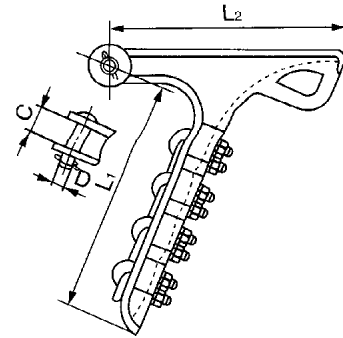

Cat No	Conductor Dia. (mm)	Dimensions(mm)				U Bolt (pc.)	U.T.S (KN)	Weight (Kg)
		D	C	L1	L2			
NLL-1	5.1-11.4	16	19	126	108	2	40	0.5
NLL-2	10.9-15.5	16	24	176	187	2	40	1.8
NLL-3	15.0-21.0	16	17.5	190	203	3	70	1.9
NLL-4	18.1-24.8	16	30	298	284	4	90	4.1
NLL-5	24.0-30.0	24	36	446	342	5	120	7.0
NLL-1A	4.57-13.21	16	16	114	137	2	35	1.0
NLL-5A	8.0-30.0	18	32	190	238	3	80	3.5
NLL-6A	30.0-38.0	18	39	260	245	3	80	4.2

The body and keeper are made of aluminum alloy,. the cotter-pin is made of stainless steel. Other parts are made of hot-dip galvanized steel .

8.Malleable Iron Strain Clamp (bolted type)

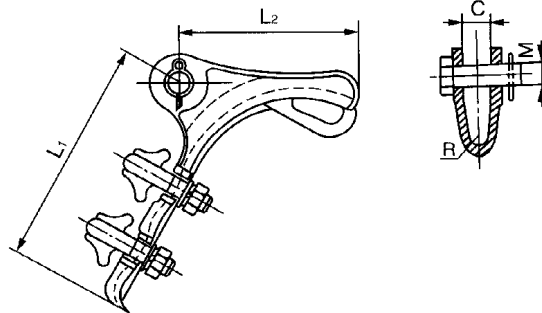

Cat No	Conductor Dia. (mm)	Dimensions(mm)					U Bolt		U.T.S (KN)	Weight (Kg)
		M	C	L1	L2	R	Q'ty	Dia.(mm)		
NLD-1	50-10.0	16	18	150	120	6.5	2	12	20	1.3
NLD-2	10.1-14.0	16	18	205	130	8.0	3	12	40	2.1
NLD-3	14.1-18.0	18	22	310	160	11.0	4	16	70	4.6
NLD-4	18.1-23.0	18	25	410	220	12.5	4	16	90	7.1

The body and keeper are made of malleable iron,. the cotter-pin is made of stainless steel .Other parts are made of hot-dip galvanized steel .

9. Strain Clamp (bolted type)

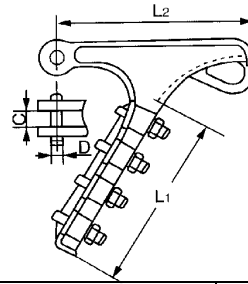

Cat No	Conductor Dia. (mm)	Dimensions(mm)				U Bolt No.	U.T.S (KN)	Weight (Kg)
		D	C	L1	L2			
NLL1-1	5.1-11.4	16	19	108	126	2	40	1.7
NLL1-1.7	4.6-13.2	16	14	80	100	2	40	1.3
NLL1-2	8.9-18.5	16	24	187	176	2	40	3.2
NLL1-2C	10.9-15.5	16	28	140	200	2	40	3.2
NLL1-2D	11.7-21.8	16	30	140	200	2	40	3.1
NLL1-2M	6.54-9.27	16	20	127	156	2	40	3.0
NLL1-3	5.1-14.5	16	17	187	203	3	70	5.3
NLL1-3A	11.68-21.84	16	21	128	126	3	70	3.1
NLL1-3N	12.6-23.4	16	22	150	130	3	70	3.2
NLL1-3U	9.5-21	16	25	120	156	3	70	3.8
NLL1-4	9.1-21.8	16	26	275	292	4	90	7.4
NLL1-4A	18.1-24.8	18	30	298	284	4	102	7.4
NLL1-5	24.0-30.0	24	36	446	342	5	120	9.2
NLL1-5A	25.2-36.2	18	32	235	280	5	80	8.3
NLL1-6A	25.0-38.0	18	36	245	300	6	80	9.8

The body is made of malleable iron and the keeper is made of aluminum alloy,. the cotter-pin is made of stainless steel. Other parts are made of hot-dip galvanized steel .

10. Strain Clamp (bolted type)

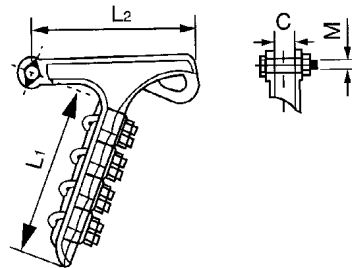

Cat No	Conductor Dia. (mm)	Dimensions(mm)				U Bolt No.	U.T.S (KN)	Weight(Kg)
		M	C	L1	L2			
NLT-1U	5.1-11.4	16	19	126	108	2	40	0.5
NLT-2U	8.9-18.5	16	14	176	187	2	40	1.8
NLT-3U	5.0-15.0	16	17.5	190	203	3	70	1.9
NLT-4U	12.1-21.8	16	30	298	284	4	90	4.1
NLT-5U	18.0-30.0	24	36	446	342	5	120	7.0

The body is made of malleable iron , the keeper and liner of clampare made of aluminum alloy,. the cotter-pin is made of stainless steel. Other parts are made of hot-dip galvanized steel .

11. strain Clamp (straight line type)

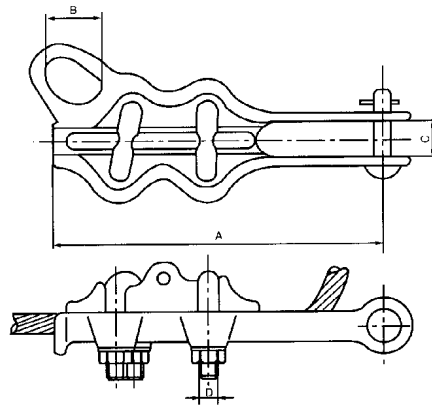

Cat No	Conductor Dia. (mm)	Dimensions(mm)				U Bolt No.	U.T.S (KN)	Weight (Kg)
		A	B	C	D			
NLZ-1L	3.8-9.4	114	25.4	18	16	2	20	0.60
NLZ-2L	5.8-10.4	206	25.4	19	16	2	35	0.84
NLZ-3L	7.6-15.2	210	22.2	22	16	2	45	1.05
NLZ-4L	11.7-22.4	260	25.4	29	16	2	45	1.34

Clamp body and keeper are made of aluminum alloy. cotter-pin is made of stainless steel.

Other parts are made of hot-dip galvanized steel

12. Aluminum Alloy Strain Clamp (straight line type)

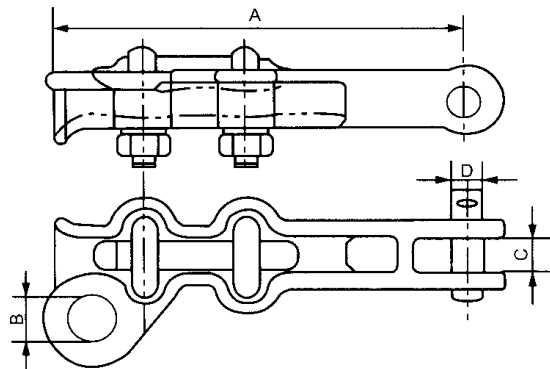

Cat No	Conductor Dia. (mm)	Dimensions(mm)				U Bolt No.	U.T.S (KN)	Weight (Kg)
		A	B	C	D			
NLZ-1T	3.8-9.4	114	25.4	18	16	2	30	1.2
NLZ-2T	5.8-10.4	206	25.4	19	16	2	45	1.68
NLZ-3T	7.6-15.2	210	22.2	22	16	2	55	2.10
NLZ-4T	11.7-22.4	260	25.4	19	16	2	55	2.68

The body and keeper are made of hot-dip galvanized malleable iron. cotter-pin is made of stainless steel. Other parts are made of hot-dip galvanized steel .